

Letter Mailing Specifications

Oversize Postcards and Envelopes

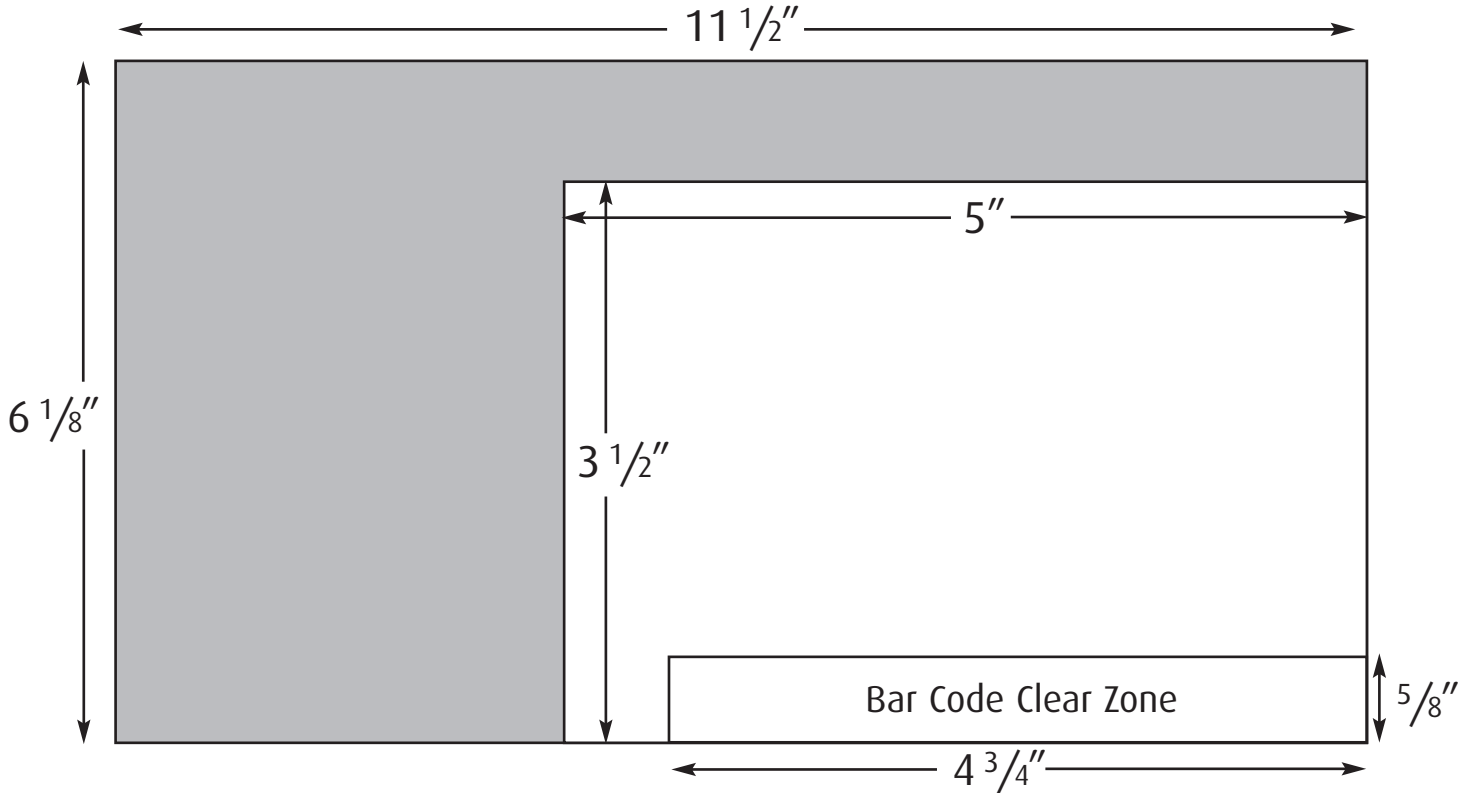

Bar Code Clear Zone is where postal bar code may be sprayed.
Do not place text in this zone.

Minimum Size 3 1/2" x 5"
Maximum Size 6 1/8" x 11 1/2"

Automation Aspect Ratio
 Length divided by height must be between 1.3 and 2.5. If outside this aspect ratio, cannot mail at automation rates and subject to surcharges.

Minimum Thickness 7 pt up to 4 1/4" x 6"
 9 pt over 4 1/4" x 6"

Maximum Thickness 1/4"

Maximum Weight
 Automation 1st Class 3.3 oz.
 Automation Standard 3.5 oz.

Address Block Clear Area
 Minimum 1 1/4" x 3 5/16"
 Preferred 1 1/4" x 4"

Address Block Position
 Minimum from left or right 3/8"
 Minimum from bottom 1/2"
 Maximum from bottom to top of block 4"

Address block must run horizontal

Bar Code Specs
 Minimum distance to any type or printing, except address lines 1/8"
 Minimum distance to address lines 1/25"
 Minimum from left or right 1/2"
 Minimum from bottom 5/8"
 Maximum bottom to top of bar code 3 7/8"

